

TEMPERATURE LIMITING



NEW SINGLE LEVER WITH SECURITY

When a mechanical Single Lever Cartridge is combined with a Vernet thermostatic element, it creates THQ safety cartridges. **With this new technology, being scalded is impossible.**

/ SAFETY

- The Vernet Technology:
- limits the hot water temperature
 - ensures **antiscald security** in case of cold water failure

/ SAVINGS

Temperature is obtained with minimum water and energy

/ INTERCHANGEABLE

Directly replaces a mechanical single lever cartridge with distributor

/ EXTENDED RANGE

- available in Ø35mm or Ø40mm
- available in Single Lever or Sequential



APPLICATIONS



Shower - Washbasin - Kitchen sink - Bidet

QUALITY & CERTIFICATIONS

100% quality control: each cartridge is individually checked for leakage and antiscald function

Materials are certified to drinkable water regulation requirements

GENERAL CHARACTERISTICS

- / **Safety temperature limitation: 45°C**
or according to your requirement
- / **Temperature limitation stability**
regardless of inlet hydraulic or temperature conditions
- / Watertightness: according to **EN817**
- / High quality materials
- / **Mixing angle: 108°**

FLOW RATE VS TEMPERATURE

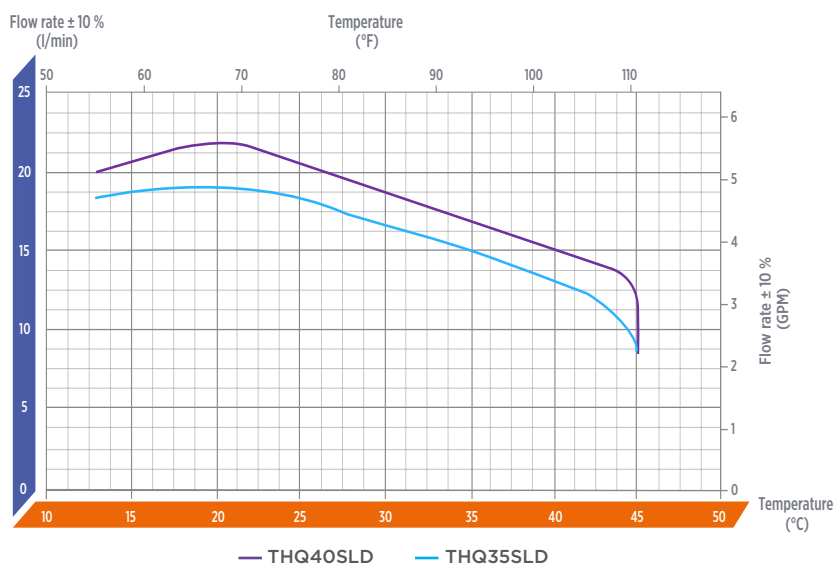

DIMENSIONS (in mm)

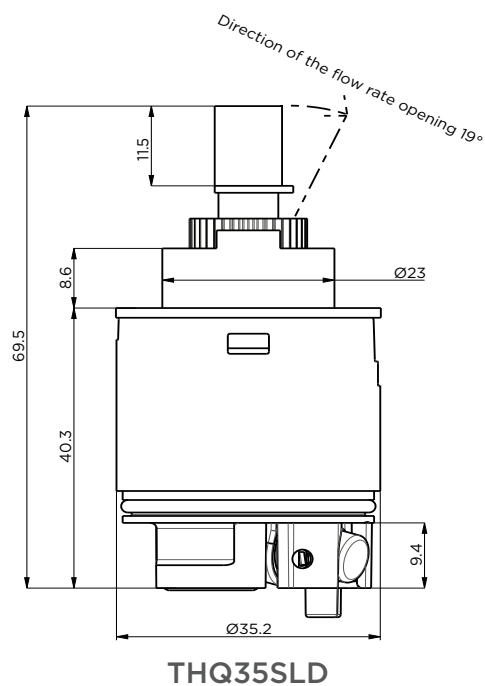
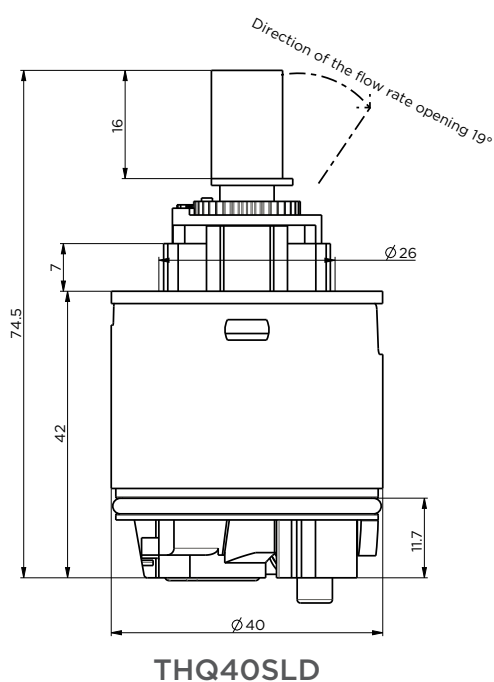

Technical drawings are available on request